

Operating Instructions

Stinger System 03-W001-0400

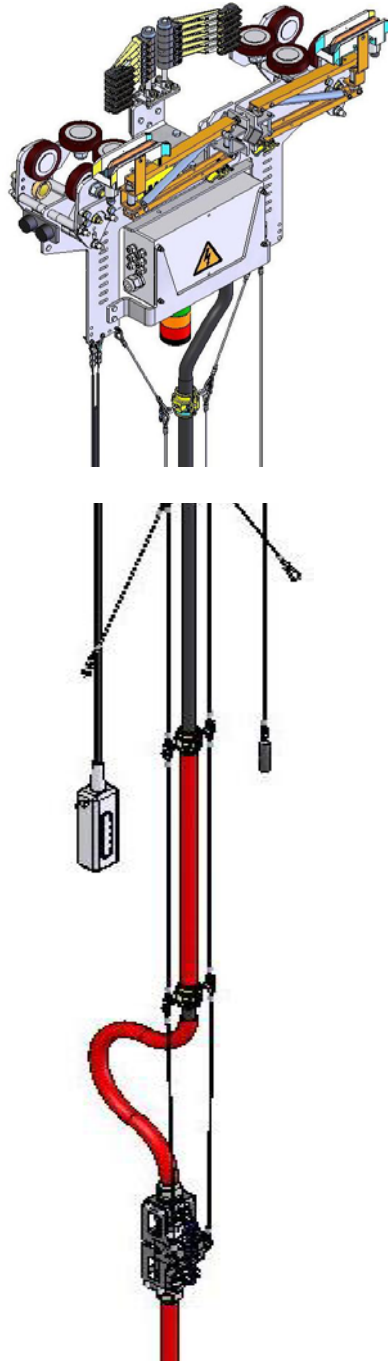
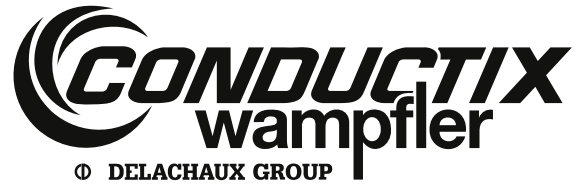

Index

Page

1	Introduction	2
2	Target Group.....	3
3	Designated application.....	3
4	General safety instructions	4
5	Technical description	8
6	Operation	9
7	Technical data.....	10
8	Transport and installation.....	12
9	Commissioning	18
10	Maintenance	19
11	Disposal	23
12	Spare parts list.....	23

1 Introduction

This operating manual is part of the Stinger System. Prior to commissioning, ensure that operating personnel has read and understood these instructions. Use the Stinger System only according to its designated application (see chapter „Designated Application“).

This documentation is protected by copyright law. The rights established herein, including translation, reprinting, the use of figures, radio transmission, reproduction using photographic or similar methods or saving in electronic format remain reserved, even for partial use.

Conductix-Wampfler reserves the right to make technical changes without informing the recipient of this document / these data. Conductix-Wampfler accepts no liability, inasmuch as this is legally permissible, for errors in this documentation or for damages that occur in connection with delivery and use of the documentation.

© Conductix-Wampfler AG 2008

2 Target Group

ONLY AUTHORIZED AND QUALIFIED MAINTENANCE PERSONNEL MAY WORK WITH THE STINGER SYSTEM.

Such persons are the target group for this manual.

A qualified person is anyone correctly trained and authorized to operate the energy supply system in compliance with relevant standards, regulations and laws. In addition, a qualified person has the special education and skills necessary to recognize and avoid risks and possible dangers which may occur during operation.

Maintenance and repair on the electrical system and on electrical equipment of the Stinger System may only be performed by authorized and qualified technicians in compliance with the relevant electrotechnical rules, regulations and laws.

Maintenance and repair on the mechanical system may only be performed by authorized and qualified persons in compliance with the relevant technical standards, regulations and laws.

3 Designated application

The Stinger System is a power supply for rail vehicles, which are located in a maintenance and repair area and separated from their main power supply.

The system supplies sufficient power for operating the onboard systems and for moving the rail vehicle slowly by drive*, within a limited area.

During operation, the load on the Stinger System must not exceed a certain limit*.

The system is a passive power supply. All electric and electronic control, surveillance and protection functions are not part of the system and under the responsibility of the operator.

NOT a designated application is ...

- ... if the rail vehicle is moved and the speed exceeds a certain limit*.
- ... if the rail vehicle is moved out of the defined maintenance and repair area.
- ... if the electric load on the Stinger System exceeds a certain limit*.
- ... if electric loads are connected to the Stinger System, which are not designated to the rail vehicle.
- ... if the length of the Stinger connection cable has changed.
- ... if the length of the Stinger connection cable has shorten by loops or by coiling or binding of cable sections.
- ... if the Stinger connection cable is coiled around other objects.
- ... if the Frangible Link is by-passed or removed mechanically.
- ... if the Stinger connection cable is separated at the Frangible Link.
- ... if the plastic shear rod of the Frangible Link is removed and a third party part is installed (e.g. a metal rod).

Stinger System

03-W001-0400

- ... if the Stinger connection cable is removed from the rail vehicle under load.
- ... if the Stinger System gets in contact with liquids (water, detergents...). Do not use a high pressure cleaner nearby !
- ... if inappropriate cables are used
- ... if atmospheric conditions (including a change to projected physical location) are changed
- ... if technically inappropriate guide systems (such as inappropriate or corroded track beams, poorly aligned girder joints, etc.) are used
- ... if there is a presence of projecting edges on the surrounding steel framework at insufficient distance from the cable trolley

* = refer to chapter „Technical data“

The manufacturer is in no way liable for damages to the system or third parties resulting from non-intended use.

The Stinger System is built in accordance with recognized safety/technical regulations using current technology and has been checked for safety compliance by the manufacturer. Only Stinger Systems that are in good technical condition may be employed for their intended use. These may only be operated by personnel aware of safe operating practices and possible hazards. Intended use of the system also includes the observance of manufacturer operation, service, and maintenance requirements.

4 General safety instructions

The following symbols and references are used in this manual to give instructions and warnings (cautions) of particular importance. These must always be strictly observed!



NOTE:

Refers to special information on how to use the equipment safely and efficiently.



CAUTION:

Warns of general dangers. Danger of injuries and damage to property. Take care!



CAUTION:

Warns of danger of electrical shock from live equipment.

The operating instructions must always be kept at an on-site location near the Stinger System where they can be readily accessed. In addition to the operating instructions, general regulations regarding accident prevention and environmental protection are to be observed.

Stinger System

03-W001-0400

The operator must observe following for operation of a Stinger System:

- Installation, activation, maintenance and operation of the Stinger System must be performed by sufficiently qualified and trained specialists.
- Before beginning work, operation and maintenance personnel must have read and understood the operating instructions and safety regulations, in particular. Protective gear for operation and maintenance personnel must be provided and used.
- The system operator or his/her representative is to supervise machine operation to ensure that personnel use caution when working on or with the system.

Special safety notes

Transport / Installation:

- Individual parts and larger assembly groups are to be secured on suitable hoisting devices or load-carrying equipment that are in good working order and have sufficient load capacity.

For electrical and mechanical connections:

- Connections are only to be made by personnel specially trained for the given task.

For commissioning and operation:

- Before initial commissioning and daily start-up, a visual check and predefined inspection procedure is to be performed as described in chapter 4.
- Any procedures that could negatively affect safety are to be avoided.
- The system should only be operated with functional protective gear and safety devices.
- Notify the responsible party immediately in case of damage to the Stinger System.
- Protect the Stinger System from accidental or unauthorized operation.

For cleaning / service / repair / maintenance / reconditioning:

- Turn off power supply and ensure that no unauthorized activation is possible.
- When installation tasks are carried out above eye level, use proper climbing aids and working platforms.
- Do not climb on machine components.
- Check cables for wear or damage.
- Ensure that exhaust, collection and disposal of process materials be done in a safe and environmentally-friendly manner.
- Safety devices that are removed for installation, service or repair must be remounted and inspected after work is completed.
- Observe the inspection and maintenance intervals
- Observe the directions in the operating and maintenance instructions for replacing parts.
- Ensure that sufficient space for maintenance work is available.
- Ensure that the Stinger System is not unexpectedly activated during maintenance work.
- Ensure that detached parts do not fall.
- Screw joints that are disconnected during maintenance work are to be rejoined and secured as instructed.
- Fasteners and seals that cannot be used again are to be replaced (such as self-locking nuts, disks, splints, O-rings, glued or microencapsulated screws).

Stinger System

03-W001-0400

- Lubrication points that are cleaned or wiped during maintenance and repair work must be re-lubricated as instructed.
- After finishing work, collect all tools and materials and check that all are present.
- Detached parts and components that were replaced are to be collected, stored in a safe place, recycled, or sent back.

Hazard areas must be identified with warning signs and be protected with barriers. Ensure that hazard area notices are observed.

Hazards can result from

- Improper use
- Failure to adequately observe safety notices
- Inadequate inspection and maintenance work

Mechanical hazards



WARNING! Bodily harm!

Unconsciousness and injury due to

- crushing, pinching, cutting, wrapping
- retracting, blunt collision, stabbing, grinding
- slipping, stumbling, falling.

Causes:

Areas where danger of crushing, pinching and wrapping exists

- Part failure or explosion

Ways to protect yourself:

- Keep floors, devices, and machines clean.
- Repair leaks.
- Observe the required safety distance.

Electrical hazards

All errors must be analyzed before remedying the problem.

Work on electrical systems or production equipment may only be performed by specialized electricians or persons under the supervision and direction of an electrician in accordance with electrical rules (qualified personnel).



WARNING! Bodily harm!

Death due to electric shock, injury and burns due to

- Touching live sources
- Inadequate maintenance and repair
- Faulty insulation
- Short circuits

Causes:

Touching or coming too close to uninsulated current-bearing parts

- Using uninsulated tools
- Current-bearing parts that are laid bare due to insulation failure
- Inadequate safety checks after maintenance work
- Use of improper fuses

Stinger System

03-W001-0400

Ways to protect yourself:

- Ensure that current to machines and system parts that are to undergo maintenance work is turned off and protected against reactivation.
- Check parts to ensure that they are free of current. Cover and isolate nearby live parts.
- Check electrical equipment regularly
- Immediately replace loose or damaged cable or lines
- Always replace blown fuses with identical fuses
- Avoid touching live parts
- Use insulated tools.

Repeat inspections

Every owner is to record all inspection, service and maintenance tasks in a machine book in an orderly manner. This is to be confirmed by a technical expert. In case of inaccurate or missing entries, the warranty is rendered null and void.



CAUTION! System or property damage!

Devices and systems are to be periodically inspected by an expert. In general, visual and functional checks are to be performed. The condition of components with regard to damage, wear, corrosion or other damage is to be determined. Furthermore, completeness and functionality of the safety equipment is evaluated. To better evaluate the wear and tear of parts, disassembly may be required.

CAUTION! System or property damage!

All regular inspections are to be performed by the owner.

Stinger System

03-W001-0400

5 Technical description

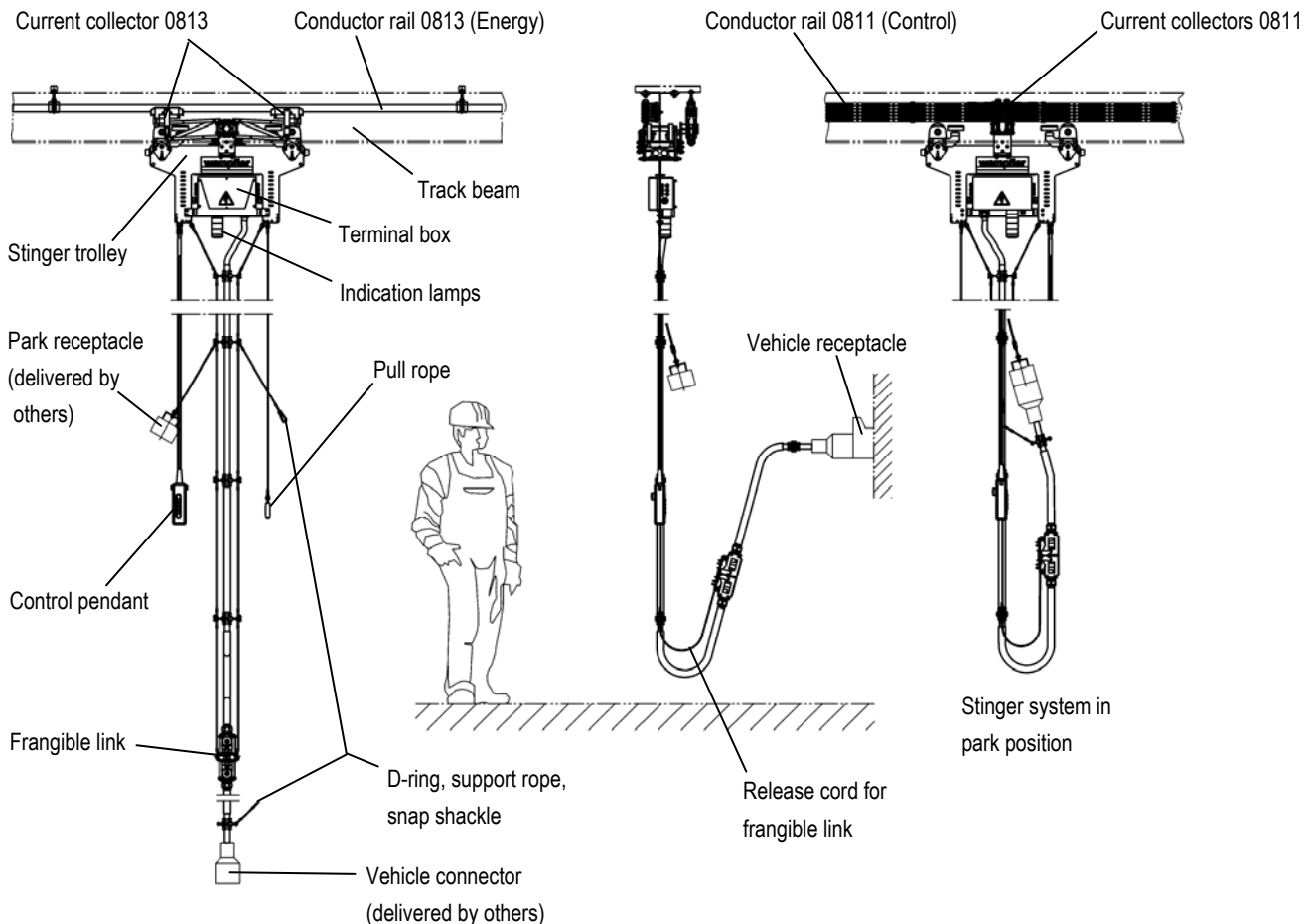

The current collector trolley can be moved manually along the track beam by pulling the rope. The track beam is located above the maintenance-/repair area and in parallel to the rail vehicle. The conductor rail provides power and control signals to the Stinger System. The track beam with the conductor rails is called „road“. There are two Stinger Systems in a road, providing energy to a rail vehicle each. From the current collectors energy and control signals are conducted through the terminal box into the connection cable. The connector at the end of the cable is plugged into the receptacle at the rail vehicle. The Stinger System can be switched „ON“ and „OFF“ with the aid of the control pendant. Lamps at the current collector trolley and at the control pendant indicates the operating status. If the Stinger System is not used, the connector must be plugged into a park-receptacle, located at the connection cable support. Then the connection cable is hanging with a loop above the ground.

The Stinger System is equipped with a Frangible Link for the case of an emergency. If the rail vehicle moves out of the maintenance-/repair area, the connection cable is separated at the Frangible Link, before a high traction force causes a major damage on the Stinger System. If traction force exceeds a certain limit *, the Frangible Link disconnects at first the control circuit and then, after a short time, the energy line. This measure prevents building up an electric arc, which can injure personnel. Then both Stinger Systems in the road will be switched OFF.

* = Release traction force: Refer to item 7 "Technical data", Frangible Link

Stinger System

03-W001-0400



CAUTION! Danger of accidental releasing of the Frangible Link!
The traction force on the connection cable must not exceed 400 N.



CAUTION! Danger of electrical shock!
Do not open the Frangible Link!



CAUTION! Danger of injuries and damage to property caused by falling objects!
If the Frangible Link is removed or out of order (e.g. Frangible Link is by-passed or removed mechanically, connection cable has shorten by loops or by coiling or binding of cable sections, the plastic shear rod has been exchanged for a metal rod), the connection cable will not be separated in the event of an emergency. Parts of the Stinger System can break down by traction force exceeding a certain limit.

6 Operation

Both connectors on one road have to be plugged into a vehicle receptacle or "park" receptacle to allow the traction supply to be energised. Always lock connectors.

Both connectors on one road may be connected to the vehicles. In this configuration, both energy supplies will be switched ON or OFF, if one of the control panels is operated.

There are the following operating states:

1. Both Stinger Systems are switched off. The green lamps are active. Both systems are not energised.
2. Stinger System 1 is connected to the vehicle and active and Stinger System 2 is in Park-position*. The red lamps are active. Both systems are energised.
3. Stinger System 2 is connected to the vehicle and active and Stinger System 2 is in Park-position*. The red lamps are active. Both systems are energised.
4. Both Stinger Systems are connected to a vehicle and active. The red lamps are active. Both systems are energised.

* = Park-position: Connector is plugged into the Park-receptacle.



NOTE!

Prior to connecting or disconnecting the Stinger System, the supply should be switched OFF by operating the control pendant. Then, both Stinger Systems in a road will be switched OFF. Wait until the green indication lamps are active.

Stinger System

03-W001-0400

7 Technical data

Conductor rail

Power conductor rail:	Type 081315 (single pole)
Number of conductors:	1
Voltage:	750 VDC
Continuous rating:	500 A
Control conductor rail:	Type 081112 (single pole)
Number of conductors:	6
Voltage:	24 VDC
Continuous rating:	50 mA

Collector trolley

Collector trolley:	Type 03-W001-0400
Number of trolleys:	2 per road
Current collectors:	Type 081301-2x01; 2x 250 A (double collector)
Number of current collectors:	1 per trolley
Control collectors:	Type 081102-0021; 55 A
Number of current collectors:	12 per trolley (2 per conductor rail)
Voltage:	750 VDC
Continuous rating:	350 A per trolley
Wiring according to Electric scheme:	08-S210-0255
Indication lights:	"ON" – Red ; "OFF" – Green; Yellow – not used
Material terminal box:	ABS
Insulation terminal box:	VDE 0100
Protection terminal box:	IP 657 (DIN EN 60529)
Towing speed:	1.1 m/s (max.)
Pull force:	≤ 80 N
Protection:	IP 23

Control pendant

Pushbuttons:	"Start" – White; "Stop" – Red, Mushroom head
Indicator lamps:	"ON" – Red ; "OFF" – Green

Operating Instructions

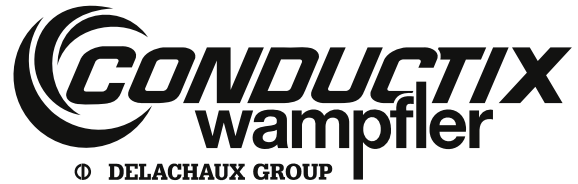

Stinger System

03-W001-0400

Connection cable

Cable type:	TXP-4 12YHRD11YH
Insulation material:	PUR
Number of strands and cross section energy:	3 x 50 mm ²
Number of strands and cross section control:	3 x 4 mm ² (one strand not used)
Diameter:	32 mm
Cable length:	Assembly type 1: 5650 mm Assembly type 2: 4750 mm Assembly type 2: 5750 mm

Frangible Link

Type:	Mechanical decontactor with separate early breake control
-------	---

Connectors

Release traction force:	400 to 1200 N
Material shear rod:	PA
Length of buffer cable loop:	200 mm
Protection:	IP 40

Vehicle connector

Type:	Hyakawa HK-5MBD (not part of Conductix-Wampfler delivery)
-------	---

Park receptacle

Type:	Hyakawa HK-403916 (not part of Conductix-Wampfler delivery)
-------	---

Environmental conditions

Temperature:	+3°C to +48°C
Humidity:	59% to 82%

The Stinger System can only be installed indoor!

8 Transport and installation

Individual parts and larger assembly groups are to be secured on suitable hoisting devices or load-carrying equipment that are in good working order and have sufficient load capacity.

Track beam

The following procedures are to be observed when installing the track beam:



CAUTION! System or property damage!

In general, track beams are to be protected from corrosion using appropriate measures.

The running surfaces of the main rollers and the horizontal guide rollers must be plane, clean and free of objects or defects that could damage the rollers (scratches, cracks, holes, uneven segments, etc.).

If multiple beams are welded together, they must all have the same measurements and positional tolerances.

The beam flanges are to be aligned with particular care in horizontal and vertical planes.

Track beams that have been damaged during transport or rolling are not permitted for use.

Modified areas (from welding, sanding, etc.) on the track beam are to be protected from corrosion with appropriate measures.

Smoothing of welded track beams



CAUTION! System or property damage!

Bumps and uneven areas on all sides of the welded track beams are to be sanded smooth for a length of 100 mm.



NOTE!

Required tools and materials.

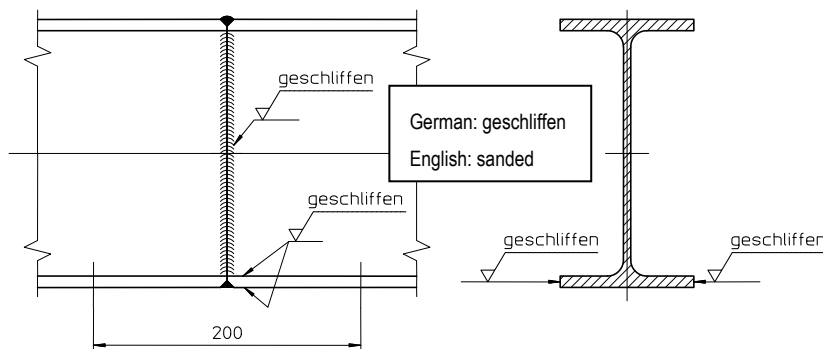

Stinger System

03-W001-0400

Use of even welded track beams



CAUTION! System or property damage!

Welded joints on the track beams must be even at points that could come into contact with the cable trolleys. Fasteners and suspended objects that could come into contact with the cable trolleys are not permitted.

No uneven areas, fasteners, suspended objects, etc.

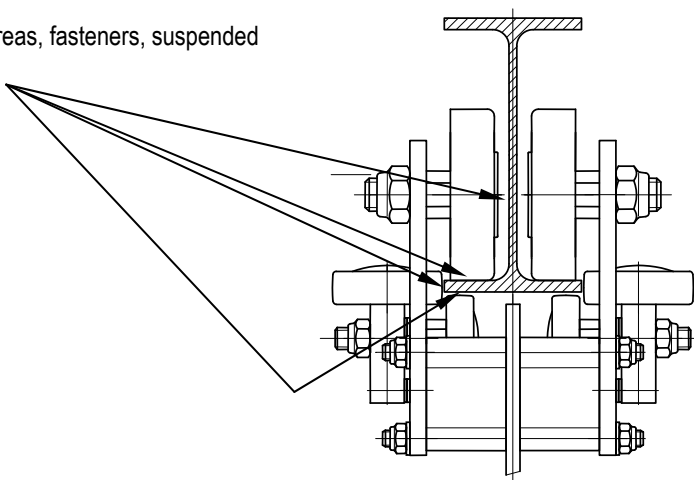

Girder joint for non-welded track beams



CAUTION! System or property damage!

For non-welded girder joints, the gap between girders must not exceed 8 mm. The cut is at a 45° angle.



NOTE!

Required tools and materials.

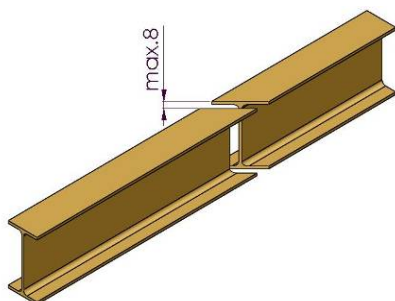

Stinger System

03-W001-0400

Girder joint for non-welded track beams



CAUTION! System or property damage!

For non-welded girder joints, the horizontal and vertical separation between girders must not exceed 2 mm. Transitions must be ground smooth within about 100 mm of the beginning of the cut. All transitions must be beveled and rounded.



NOTE!

Required tools and materials.

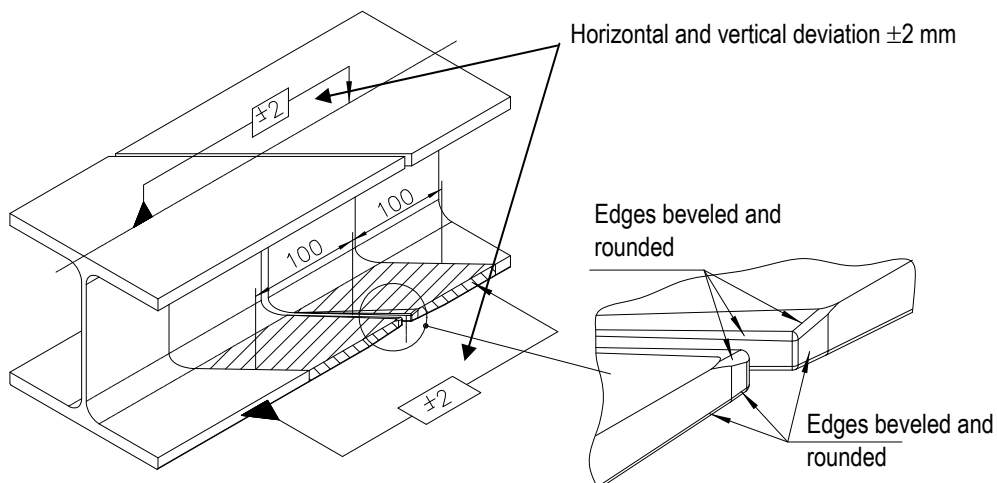

Horizontal deviation of track beams



CAUTION! System or property damage!

The horizontal deviation over the length of the track beam may not exceed ± 5 mm. For lengths shorter than 2 m, deviation may not exceed ± 2 mm.



NOTE!

Required tools and materials.



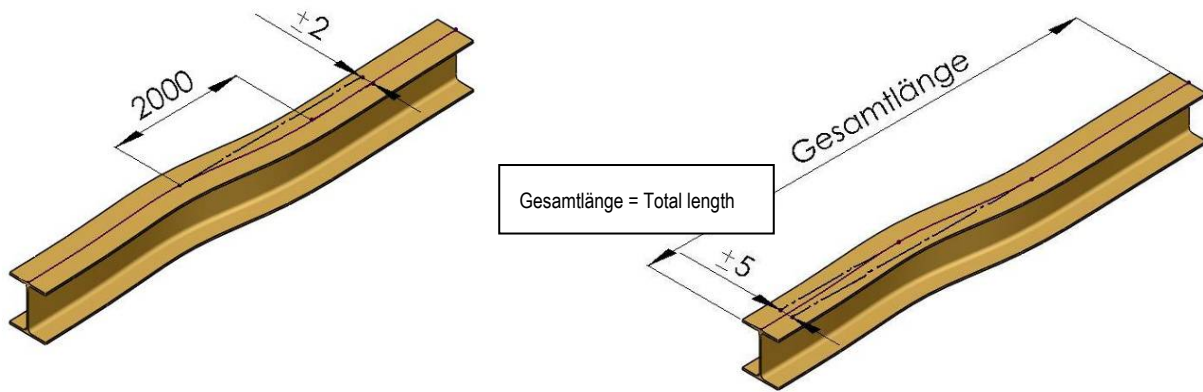

Vertical deviation of track beams



CAUTION! System or property damage!

The vertical deviation over the length of the track beam may not exceed ± 5 mm. For lengths shorter than 2 m, deviation may not exceed ± 2 mm.

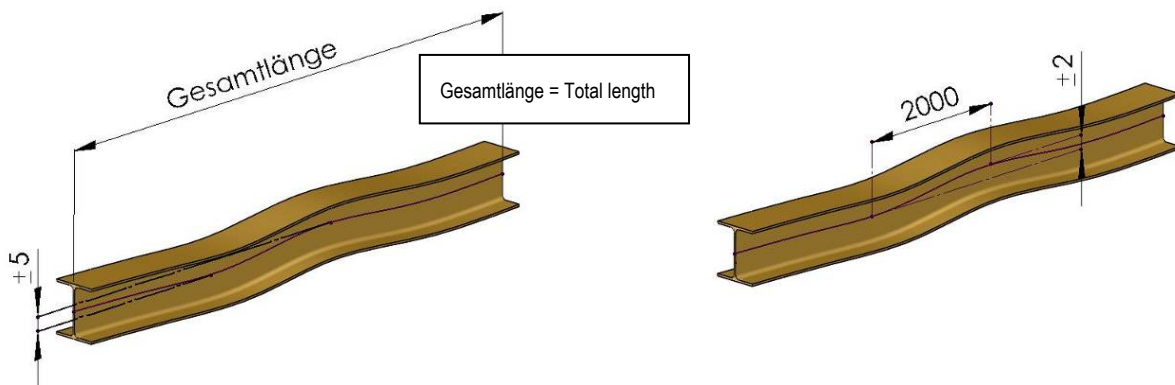

Stinger System

03-W001-0400

C-rails and hanger clamps



CAUTION! System or property damage!

Position of the C-rail and the hanger clamps has to be respected with ± 2 mm.



NOTE!

Required tools and materials.

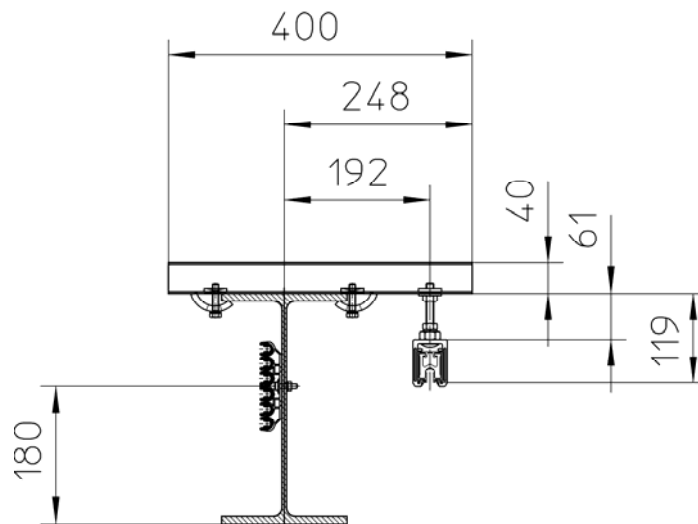

Conductor rails



CAUTION! System or property damage!

Position of the conductor rails has to be respected with ± 2 mm.



NOTE!

For the installation of the conductor rails refer to separate installation instructions MV0813-0008-E and MV0811-0001-E.

Stinger System

03-W001-0400

Collector trolley



CAUTION! System or property damage!

During installation of the collector trolley on the track beam, keep attention on the pre-installed current collectors. The collector heads could crash into the track beam and become damaged. Pull the collector heads away from the track beam during installation. Secure collector heads (e.g. with cable ties).



NOTE!

Required tools and materials

For the adjustment of the current collectors refer to separate installation instructions MV0813-0008-E and MV0811-0001-E.



The position of the current collectors has to be respected with ± 2 mm in relation to the conductor rails. Adjust position of the current collectors if necessary.

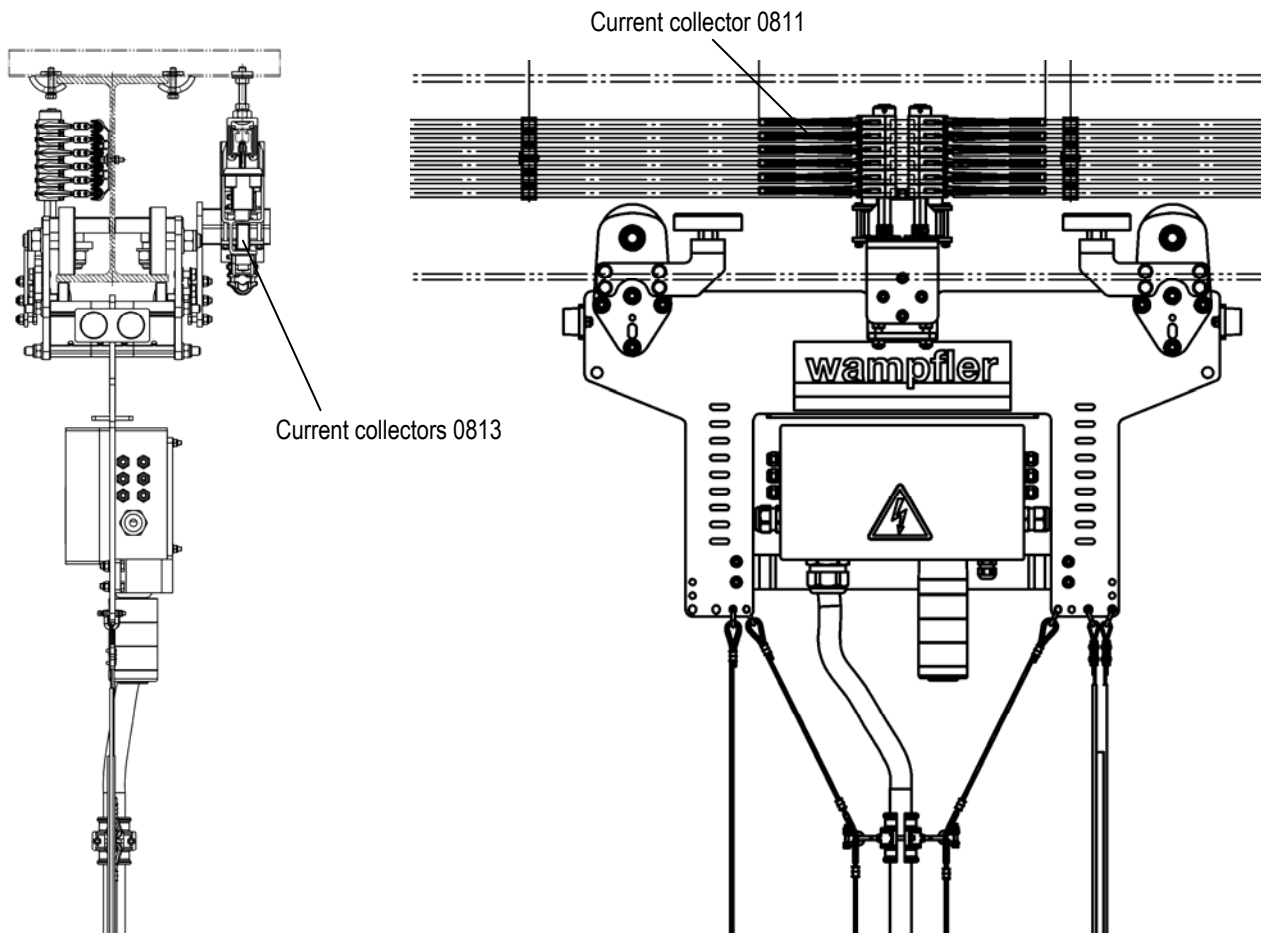

9 Commissioning

The Stinger System is commissioned together with the system operator and is documented. All necessary personnel for commissioning including crane operators, electricians and installation technicians are to be provided by the system operator for the course of commissioning. Free access to the system must be provided.

After successful commissioning, Conductix-Wampfler will receive a final handover document that is authorized by the system operator indicating that the system meets all requirements.

Inspections after installing the Stinger System

- Check the cable trolley for proper condition, function and movement, firm seating and for deformations.
- Check electrical connections and supplies for secure guiding and seating.
- Check mechanical and electrical installation.
 - Refer to Electric scheme 08-S210-0255 and drawing 08-S261-1358
- Check functionality of track beams.
- Check the steel construction for projecting edges, firm seating and mobility.

Functional testing of the Stinger System

- For commissioning, the Stinger System must be operated with a nominal load.

Operating the Stinger System

- For operation, it is mandatory that the safety notices of the operating manual are observed.

10 Maintenance

In order to retain warranty rights and to avoid damage, the system operator is responsible for performing the following maintenance tasks. Inspection, service and repair are to be performed and documented by qualified specialists.



CAUTION! Danger of injury through electric shock!

Prior to inspection, maintenance or repair on the conductor rail, the system must be disconnected from the main power supply and secured against unauthorized, accidental and/or improper reactivation. If, in special situations, there is no main switch, the disconnection from the power supply is to be handled according to specifications. The parts that have been disconnected must first be checked to ensure they are not carrying current, next grounding, and finally shorts. Isolate neighboring parts that are carrying current!

Before each start-up, an insulation check must be performed in accordance with the local technical standards, specifications and laws.

The safety regulations detailed in the relevant specification documents are applicable as well as the country-specific regulations for working on electrical devices/systems (e.g. VDE/UVV/VBG4).

Applicable are those safety regulations issued by the particular systems operator with regards to entering the facilities and working on the systems. Maintenance and repair must only be performed by appropriately trained expert personnel in accord with the respective technical standards, regulations and laws.

Maintenance and repairs on the electrical system of the device must only be performed by qualified electricians in accord with the respective electrical standards (e.g. VDE, IEC) and country-specific regulations and laws. Conductor rails are part of the electrical system and must therefore be regularly and repeatedly checked in accordance with the accident prevention regulations (e.g. VBG4).

Only genuine Conductix-Wampfler replacement parts must be used. When using other components, Conductix-Wampfler is unable to assume any responsibility whatsoever for the perfect and hazard-free functioning of the system(s) in question.

The following tasks fall under the categories "Maintenance, Service and Repair":

Stinger System

03-W001-0400

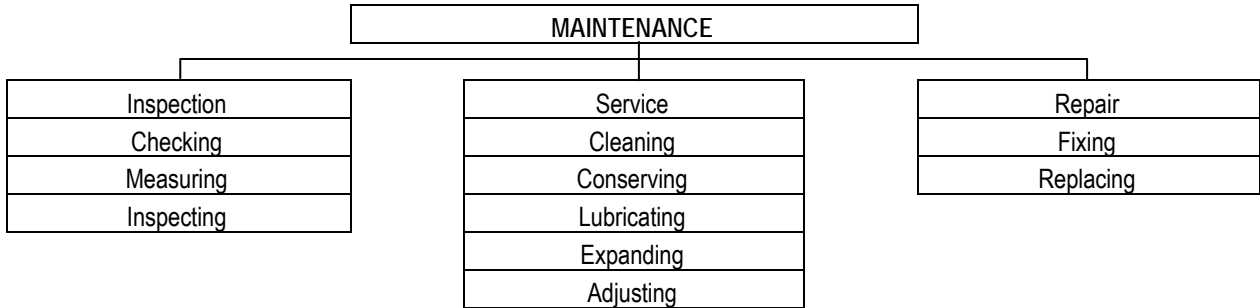

Inspection

Interval	Component	Task	Description
Every 14 days: 3 and 4 shift operation at least every 300 operating hours Every 30 days: 2 shift operation at least every 150 operating hours	Rollers	Visual inspection	- for proper condition
	Buffers		- for proper mobility
	Center plates		- for firm seating
	Cable supports		- for deformations
	Track beam		- for wear
	Cables		- for damages
	Steel ropes		- for dirt
	Fixed installation length		- for corrosion
	Installation connections		
	End stops		
	Terminal box		
	Frangible Link		
	Control pendant		
	Vehicle plug and "Park" receptacle		
	Current collectors		
	Conductor rails	Functional testing	for easy and unobstructed running of the collectors in the conductor rails. Refer to WV0800-0002-E.
	Rail connectors		of the track beam and the entire system, for dirt and corrosion that influence functionality
	Conductor rails		for easy and unobstructed running of the main rollers, horizontal guide rollers and anti-lift rollers on the track beam running surfaces.
	Current collector		Ensure that the length of the Stinger connection cable is unmodified and has not been shortened by loops or by coiling or binding of cable sections.
	Track beam and system		for easy and unobstructed connecting
Rollers			
Cable			
Vehicle connector and "Park"-receptacle			

Operating Instructions



Stinger System

03-W001-0400

		Frangible Link	Ensure that the buffer cable loop in front of the Frangible Link is existent and that the length of the cable section is 200 mm longer than the steel rope. Check, whether the plastic shear rod is undamaged and not being exchanged for a different rod (e.g. a metal rod).
		Control pendant	of the Stinger System and the Indication lamps

Should problems be identified during inspection, the service work shown in point "Service" should be performed.

Service

Interval	Component	Task	Description
Every 3 months: 3 and 4 shift operation at least every 300 hours of operation	Collector trolley	Service performed	Tighten all Fasteners.
	Vehicle connector and "Park"-receptacle		Visual examination of the housing and the insulation for damages. Both parts are not part of Conductix-Wampfler delivery. In case of damages, remove the connector, or the Park-receptacle.
	Frangible Link		Visual examination of the housing, of the pilot connectors and of the insulation for damages. Check, whether the control cable bridge is undamaged. In case of any damages, replace the complete connection cable with the Frangible Link. The plastic shear rod has to be removed. Use original Conductix-Wampfler rods only.
	Current collectors		Measure height of the carbon brushes. Replace if necessary. Refer to WV0800-0002-E
	Conductor rails		Complete service: Refer to WV0800-0002-E
Variable depends on external influences)	Complete system	Cleaning	Clean complete system Clean contact surface of conductor rails Refer to WV0800-0001

The bearings of the trolley rollers do not require service.

In case of damage of the connection cable, the complete cable with the Frangible Link has to be removed.

Stinger System

03-W001-0400

Wearing parts

Wearing parts are excluded from the warranty. This includes:

- All trolley rollers including main rollers, horizontal guide rollers, counter-pressure rollers
- Rubber or cellular buffers
- Carbon brushes
- Plastic shear rod of the Frangible Link
- Other definitions require written documentation.

Wear limits

Component	Wear limit has been reached if
Rollers	<ul style="list-style-type: none"> - the diameter of the roller has been reduced from the nominal diameter by 2 mm - sharp impressions can be seen - cracks, broken-off pieces, or embrittlements have formed on Vulkollan or Adiprene rollers, or if initial signs that the outer section is disengaging from the core appear - increased bearing play occurs due to worn ball bearings - significant lubrication leakage is seen - the rollers do not run smoothly
Buffers	<ul style="list-style-type: none"> - cracks, breaks or embrittlements are seen
Center plates and side shields	<ul style="list-style-type: none"> - corrosion protection has failed
Cable supports	<ul style="list-style-type: none"> - corrosion protection has failed - initial signs of cracks in the supports are seen - the clinch nut does not provide sufficient clamping for the cable clamp or cables
Fasteners	<ul style="list-style-type: none"> - corrosion protection has failed - connection integrity (screw joints, clamp connections, glued connections) is no longer ensured
Cables	<ul style="list-style-type: none"> - wire, shielding or jacket breakage is seen - corkscrews have formed
End clamp	<ul style="list-style-type: none"> - corrosion protection has failed - attachment to the track beam is no longer secure
Track beam	<ul style="list-style-type: none"> - corrosion protection has failed - significant tracks from the rollers of the festoon system appear
Current collectors	<ul style="list-style-type: none"> - the wearing height of the carbon brush has been reduced. Refer to WV0800-0002-E.

Stinger System

03-W001-0400

Repair

Request a customer service technician from Conductix-Wampfler for all repairs.

If qualified service technicians from the system operator perform the repairs themselves, all information contained in these operating instructions must be observed.

Conductix-Wampfler accepts no liability or responsibility for damages and production faults that result from failure to follow these operating instructions. For maintenance and repair, only use

- Suitable tools in good working order
- Original spare parts from Conductix-Wampfler or spare parts that have been explicitly approved by Conductix-Wampfler.

11 Disposal

Disposal is to be performed by qualified personnel. The Stinger System and all parts have to be cleaned prior to disposal. All parts have to be disassembled and sorted by material.

Disposal must only be performed in accord with the respective standards and country-specific regulations and laws.

12 Spare parts list

Material No.	Drawing No.	Item	Wearing part
Terminal box			
3049292	08-K040-0318	TERMINAL BOX COMPLETE	
Connection cable			
3049531	08-L020-0209-001	CABLE STINGER SYSTEM TYPE 1	
3049532	08-L020-0209-002	CABLE STINGER SYSTEM TYPE 2	
3049533	08-L020-0209-003	CABLE STINGER SYSTEM TYPE 3	
Frangible Link			
3049501	08-B001-0501	PLASTIC SHEAR BOLT	X
24514	0094-02,5X16-ST-A2F	SPLIT PIN DIN94 Ø2,5X16 A2F	X

Stinger System

03-W001-0400

Pull rope

3049293	08-S033-0001-001	ROPE STINGER SYSTEM TYPE 1	
3049294	08-S033-0001-002	ROPE STINGER SYSTEM TYPE 2	
3049295	08-S033-0001-003	ROPE STINGER SYSTEM TYPE 3	

Control pendant

3049753	08-A003-0151-001	SUSPENSION WITH CONTROL PENDANT TYPE 1	
3049754	08-A003-0151-002	SUSPENSION WITH CONTROL PENDANT TYPE 2	
3049755	08-A003-0151-003	SUSPENSION WITH CONTROL PENDANT TYPE 3	

Collector trolley

3048046	03-S016-2705	SIDE SHIELD COMPLETE 100AD/100AD/50St 0° LEFT	
3048045	03-S016-2704	SIDE SHIELD COMPLETE 100AD/100AD/50St 0° RIGHT	
3039962	030104-100.2	MAIN ROLLER Ø100 ADIPRENE	X
86114	030102-050.1	MAIN ROLLER Ø50ST	X
3943	03-P014-0008	BUMPER 40X20	X
18346	081102-0021	CURRENT COLLECTOR 0811 1P 55A PH REV	
18297	081002-1X4	COLLECTOR SHOE 0811 55A PH 68MM	X
19604	081109-4X81	CONNECTION CABLE DOUBLE INSUL. 4MM2 PH	X
18837	081301-2X01	CURRENT COLLECTOR 0813 1P 2X250A PH V GA	
44719	08-S265-0362	COLLECTOR HEAD 0813 250A	X
18302	081003-11	COLLECTOR SHOE 0813 250A	X
3051363	08-I010-0032	INSULATION PART STINGER	